

TURNING

23-2024

MAY 2024

METRIC

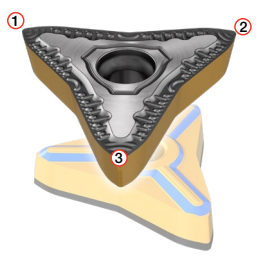
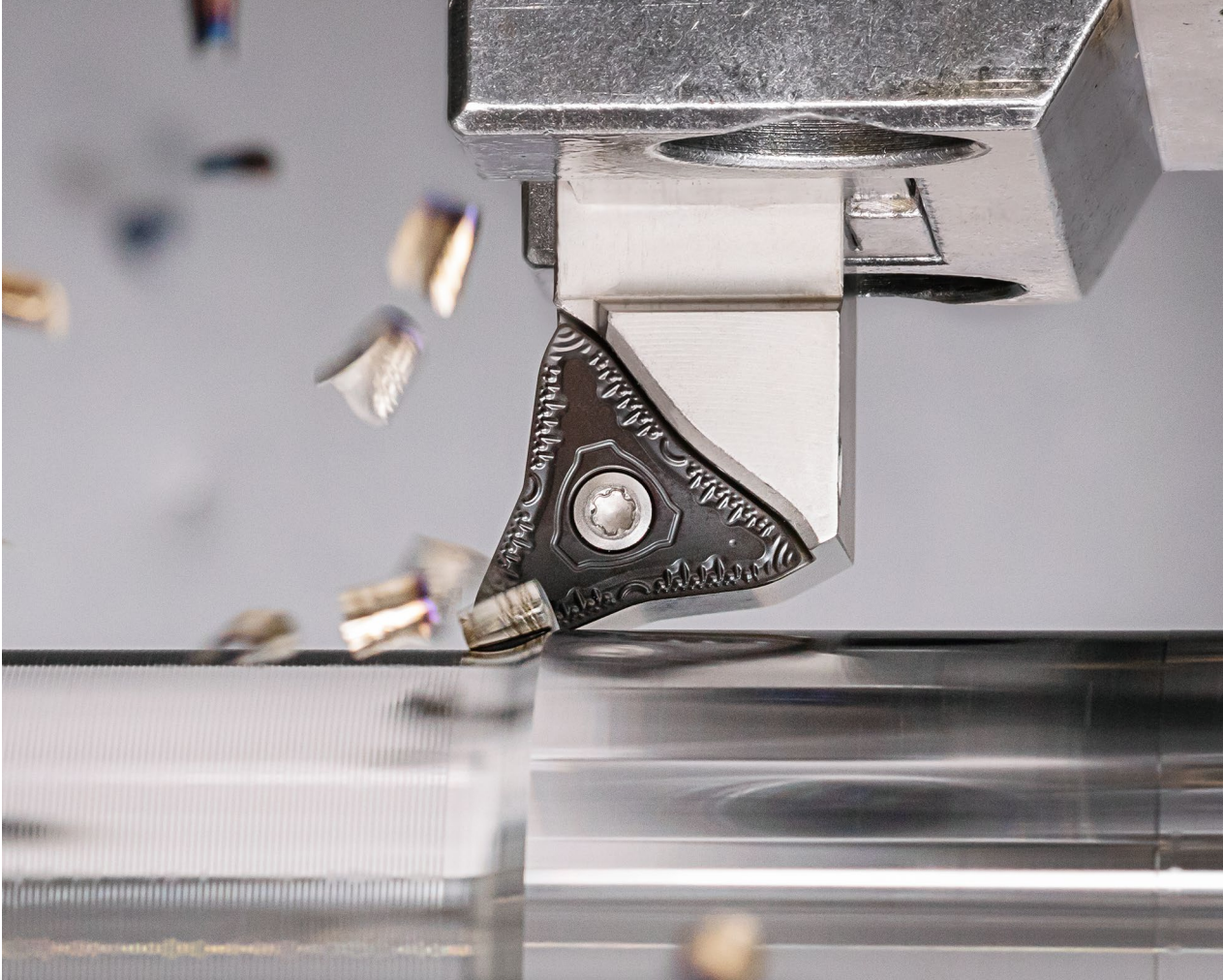

Rigid Clamping

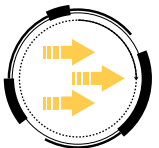

Fast Feed



High Productivity



# QUICK T LOCK

**New 3 Positive Cutting Edge Insert with Safety Lock Clamp, Suitable for Diverse Turning Directions, for Extremely High Productivity.**





Rigid Clamping

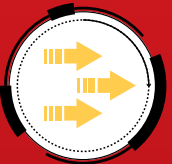

Fast Feed



High Productivity

# NPA

New Product Announcement

## QUICKTLOCK

### Highlights

#### Introducing a New Diverse Multi-Directional Turning Insert, with 3 Positive Cutting Edges and a Safety Pocket Design for Very High Feed in Back-Turning

##### Features

- Improved productivity: The **QUICK-T-LOCK** system enables multi-directional front turning, back turning, profiling and face turning that feature outstanding productivity which can be achieved with one tool.
- Unique clamping design: Features a screw lock tool with 3 bottom ridges that ensure a fixed location and high stability for machining at very high feed rate.
- Advanced chip-formers: The new **QUICK-T-LOCK** family, designed with advanced, efficient and dedicated chip-formers for high feeds specifically for backworking machining.
- Insert grades: The inserts are available with ISCAR's renowned grades for ISO-P and ISO M materials.

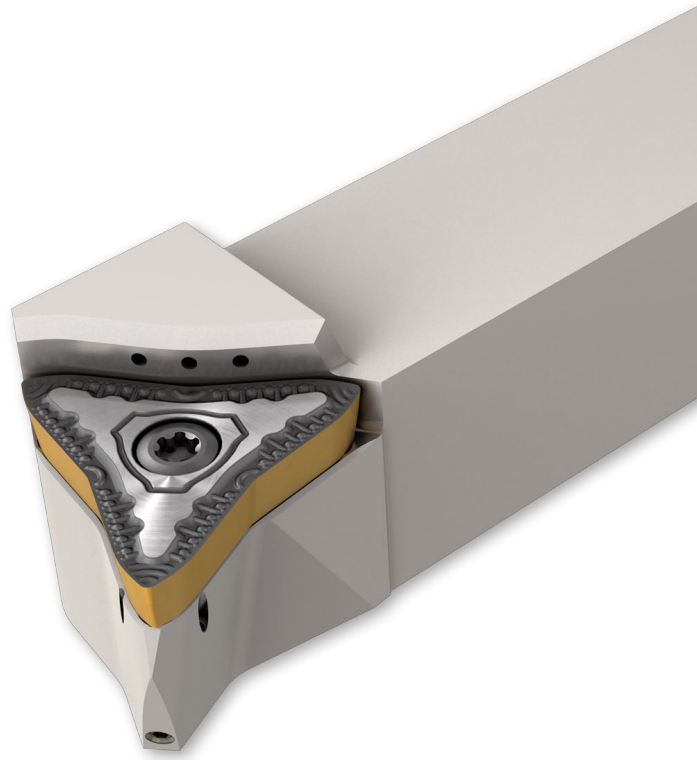
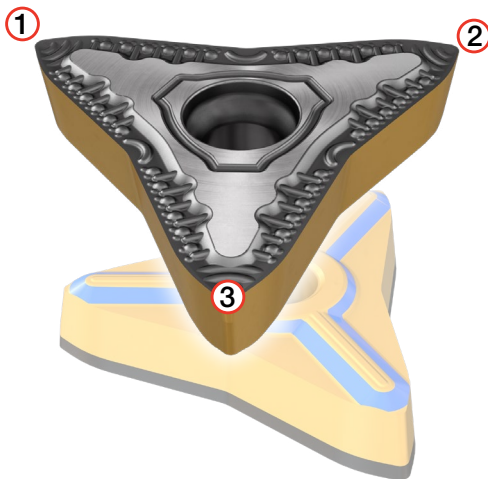

TURNING

23-2024

MAY 2024

METRIC



Rigid Clamping

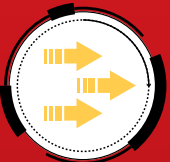

Fast Feed



High Productivity

# NPA

New Product Announcement

## QUICKTLOCK

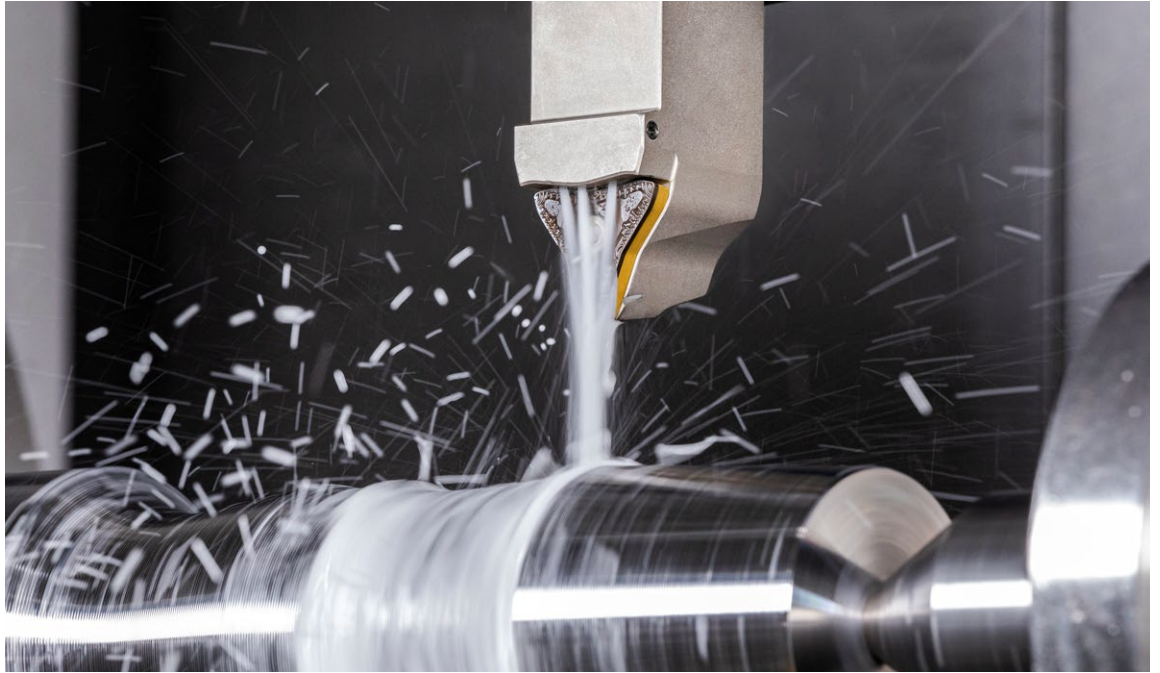

[Click for Short Video](#)

[Click for Short Video](#)

# QUICKTLOCK

### Q3-SMXCR/L-SL-JHP

Safety lock tools on which high feed positive inserts are mounted for roughing applications.

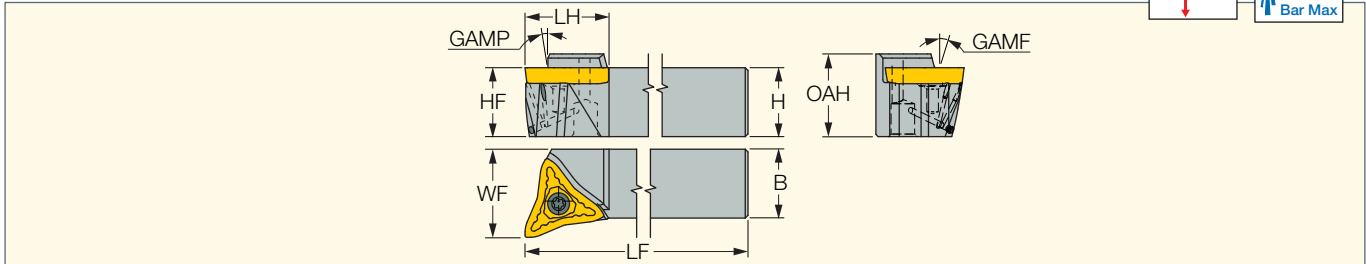

Designation	H	OAH	HF	B	LF	LH	WF	GAMP	GAMF	MIID <sup>(1)</sup>
Q3-SMXCR/L 2525M-16-SL-JHP	25.0	30.00	25.0	25.0	150.00	31.0	32.00	0.0	0.0	Q3-MCMT 1606#-R3#-SL
Q3-SMXCR/L 3232P-16-SL-JHP	32.0	37.00	32.0	32.0	170.00	31.0	39.00	0.0	0.0	Q3-MCMT 1606#-R3#-SL

•<sup>(1)</sup> Master insert identification

#### Spare Parts



Designation	Screw	T-Handle	Torx Blade	Plug	Screw 1
Q3-SMXCR/L 2525M-16-SL-JHP	SR M5-14 IP20	SW6-T	BLD IP20/M7	SR M4X4 DIN913 TL360	SR M2.5X2.5 DIN913 TL360
Q3-SMXCR/L 3232P-16-SL-JHP	SR M5-14 IP20	SW6-T	BLD IP20/M7	SR M4X4 DIN913 TL360	SR M2.5X2.5 DIN913 TL360

### Q3-SMXCN-SL-JHP

Safety lock tools on which high feed positive inserts are mounted for roughing applications

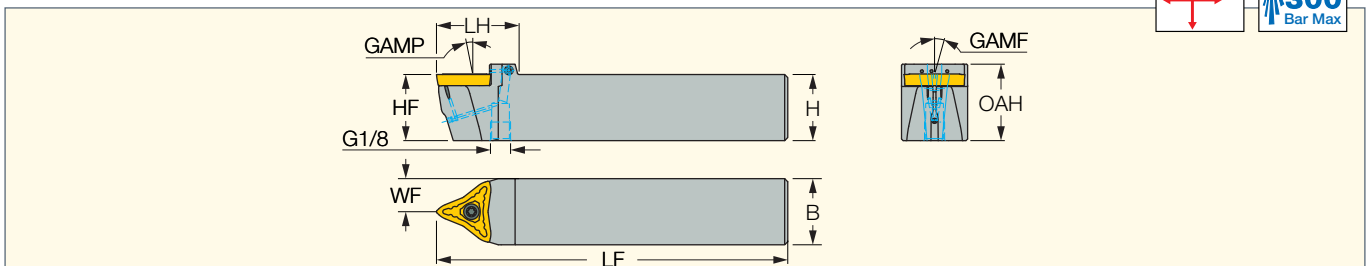
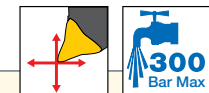

Designation	H	OAH	HF	B	LF	LH	WF	GAMP	GAMF	MIID <sup>(1)</sup>
Q3-SMXCN 2525M-16-SL-JHP	25.0	30.00	25.0	25.0	150.00	40.0	12.50	0.0	0.0	Q3-MCMT 1606#-R3#-SL
Q3-SMXCN 3232P-16-SL-JHP	32.0	37.00	32.0	32.0	170.00	40.0	16.00	0.0	0.0	Q3-MCMT 1606#-R3#-SL

•<sup>(1)</sup> Master insert identification

#### Spare Parts



Designation	Screw	Torx Blade	T-Handle	Plug	Screw 1
Q3-SMXCN-SL-JHP	SR M5-14 IP20	BLD IP20/M7	SW6-T	SR M4X4 DIN913 TL360	SR M2.5X2.5 DIN913 TL360

# NPA

## New Product Announcement

### QUICKTLOCK

TURNING

23-2024

MAY 2024

METRIC

#### C#-Q3-SMXCR/L-SL

Safety lock tools with CAMFIX shanks for high feed positive inserts for roughing applications

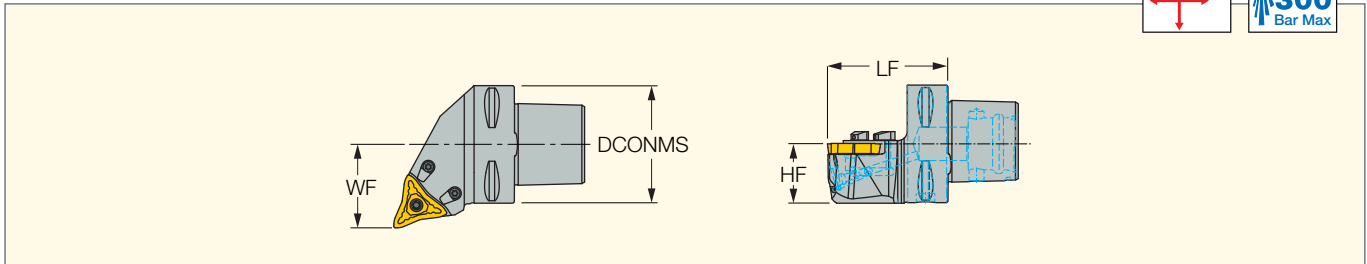

Designation	LF	HF	WF	DCONMS	GAMP	GAMF	MIID <sup>(1)</sup>
C5 Q3-SMXCR/L-35060-16-SL	60.00	25.5	35.00	50.00	0.0	0.0	Q3-MCMT 1606#-R3#-SL
C6 Q3-SMXCR/L-45065-16-SL	65.00	32.0	45.00	63.00	0.0	0.0	Q3-MCMT 1606#-R3#-SL

<sup>(1)</sup> Master insert identification

#### Spare Parts



Designation	Cooling Unit	Plug	Screw 1	Screw	T-Handle	Torx Blade
C5 Q3-SMXCR/L-35060-16-SL	CH-1.9D-JHP-A SET	SR M5X5 DIN913 TL360	SR M2.5X2.5 DIN913 TL360	SR M5-14 IP20	SW6-T	BLD IP20/M7
C6 Q3-SMXCR/L-45065-16-SL	CH-1.9D-JHP-A SET	SR M5X5 DIN913 TL360	SR M2.5X2.5 DIN913 TL360	SR M5-14 IP20	SW6-T	BLD IP20/M7

#### C#-Q3-SMXCN-SL-Y

Y-Axis Turning Tools with safety lock clamping mechanism for positive inserts, for roughing and medium applications.

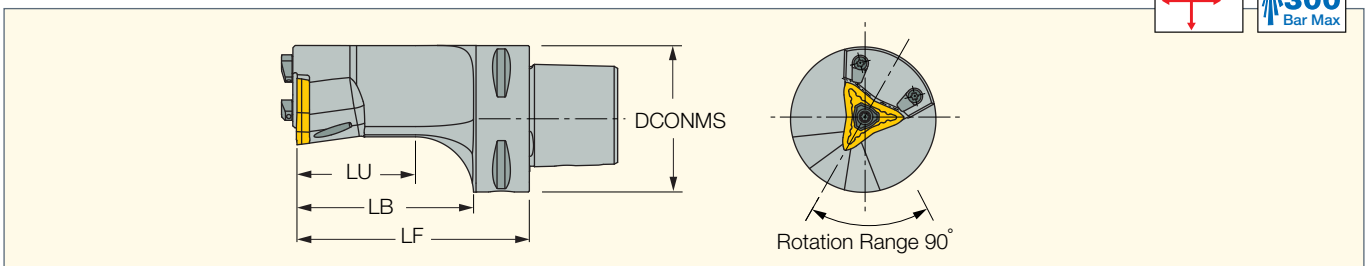

Designation	DCONMS	LU	LB	LF	CSP <sup>(1)</sup>	MIID <sup>(2)</sup>
C4 Q3-SMXCN-16-SL-H065-Y	40.00	38.50	43.50	65.00	1	Q3-MCMT1606
C5 Q3-SMXCN-16-SL-H080-Y	50.20	51.00	58.50	80.00	1	Q3-MCMT1606
C6 Q3-SMXCN-16-SL-H100-Y	63.00	51.00	76.00	100.00	1	Q3-MCMT1606
C8 Q3-SMXCN-16-SL-H100-Y	80.00	51.00	76.00	100.00	1	Q3-MCMT1606

<sup>(1)</sup> 0 - Without coolant supply, 1 - With coolant supply

<sup>(2)</sup> Master insert identification

#### Spare Parts



Designation	Screw	Plug	Torx Blade	T-Handle	Cooling Unit
C4 Q3-SMXCN-16-SL-H065-Y	SR M5-14 IP20	SR M3X3 DIN913 TL360	BLD IP20/M7	SW6-T	CH-1.9D-JHP-A SET
C5 Q3-SMXCN-16-SL-H080-Y	SR M5-14 IP20	SR M5X5 DIN913 TL360	BLD IP20/M7	SW6-T	CH-1.9D-JHP-A SET
C6 Q3-SMXCN-16-SL-H100-Y	SR M5-14 IP20	SR M5X5 DIN913 TL360	BLD IP20/M7	SW6-T	CH-1.9D-JHP-A SET
C8 Q3-SMXCN-16-SL-H100-Y	SR M5-14 IP20	SR M5X5 DIN913 TL360	BLD IP20/M7	SW6-T	CH-1.9D-JHP-A SET

# NPA New Product Announcement

TURNING

23-2024

MAY 2024

METRIC

## QUICKTLOCK

### Q3-MCMT-R3M-SL

High feed inserts with 3 reinforced cutting edges and a positive flank.

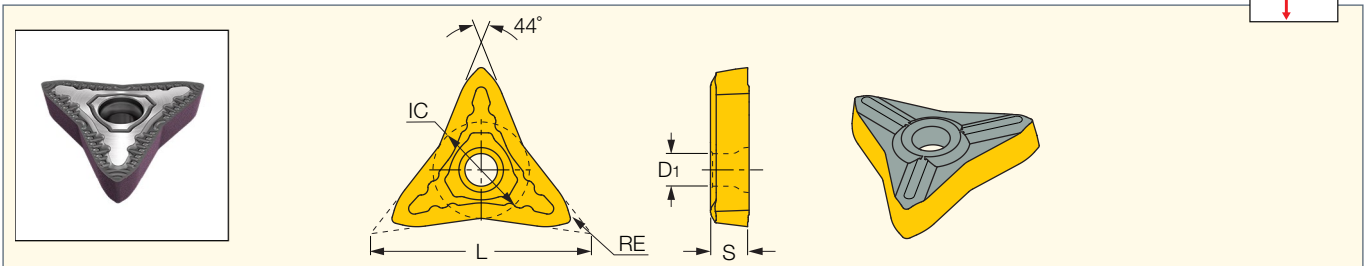

Designation	Dimensions					Tough ↔ Hard		Recommended Forward Machining Data		Recommended Backward Machining Data	
	L	IC	S	RE	D1	IC6025	IC6015	$a_p$ (mm)	f (mm/rev)	$a_p$ (mm)	f (mm/rev)
Q3-MCMT160608-R3M-SL	36.60	16.00	6.15	0.80	5.40	•	•	1.5-6.0	0.3-0.6	0.5-4.0	0.2-1.0

### Q3-MCMT-R3P-SL

High feed inserts with 3 reinforced cutting edges and a positive flank.

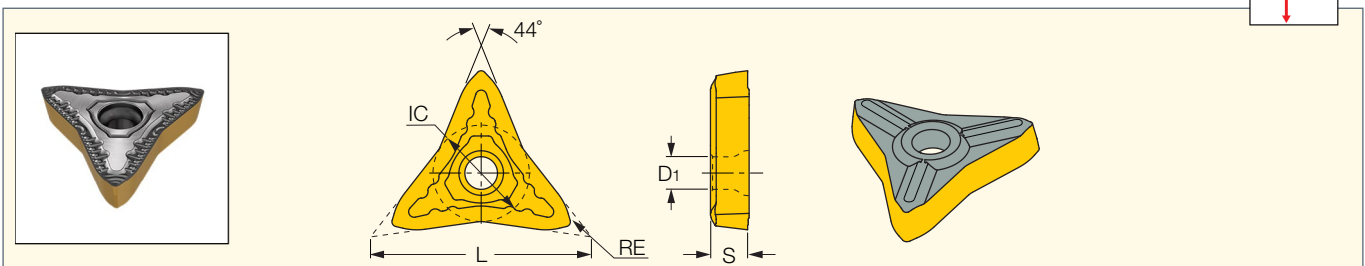

Designation	Dimensions					Tough ↔ Hard				Recommended Forward Machining Data		Recommended Backward Machining Data	
	L	IC	S	RE	D1	IC8250	IC8150	IC5010	IC5005	$a_p$ (mm)	f (mm/rev)	$a_p$ (mm)	f (mm/rev)
Q3-MCMT160608-R3P-SL	36.60	16.00	6.15	0.80	5.40	•	•	•	•	1.5-7.5	0.3-0.6	0.5-4.0	0.2-1.2

### Application Abilities

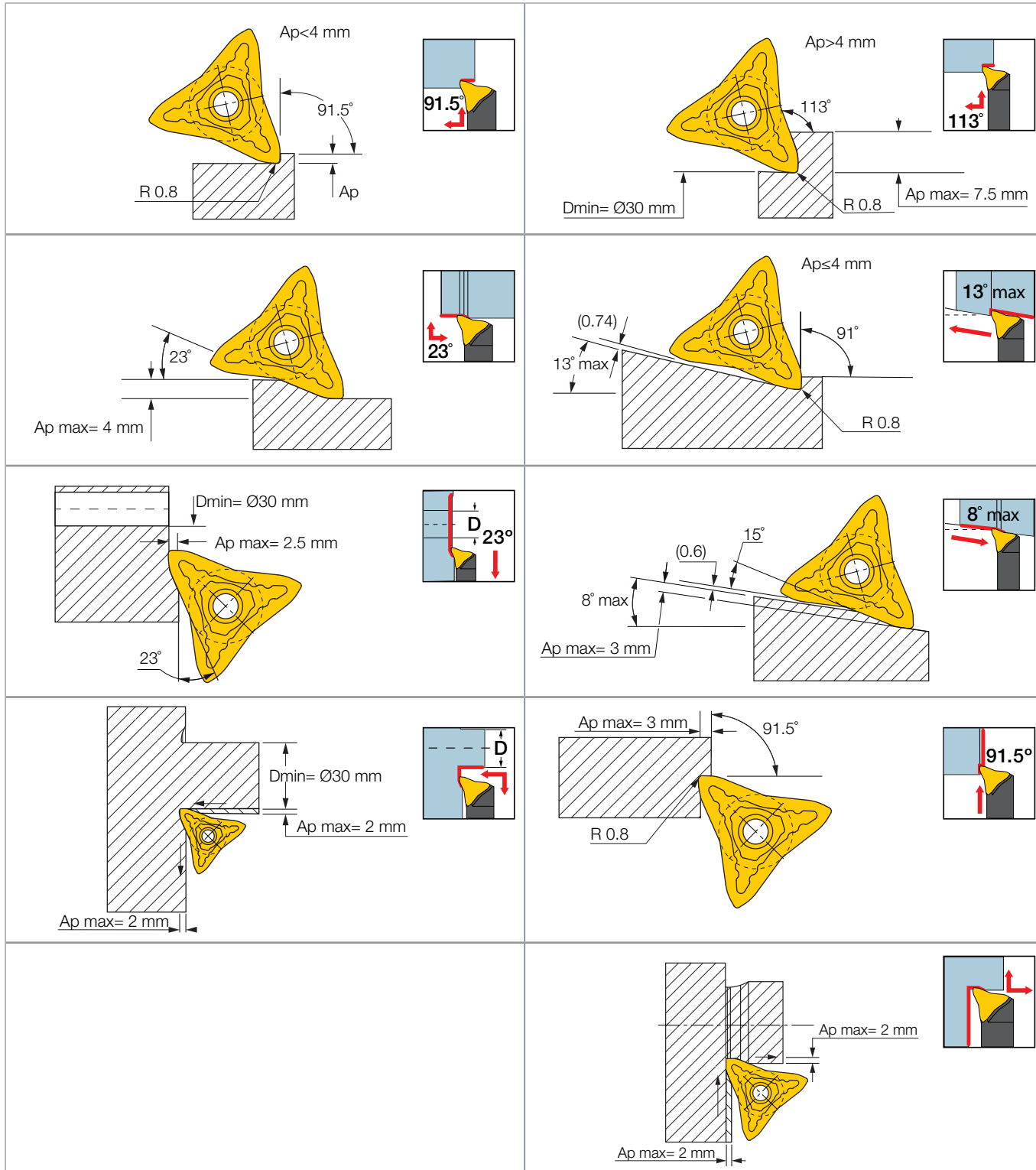

### Positioning Angle Samples

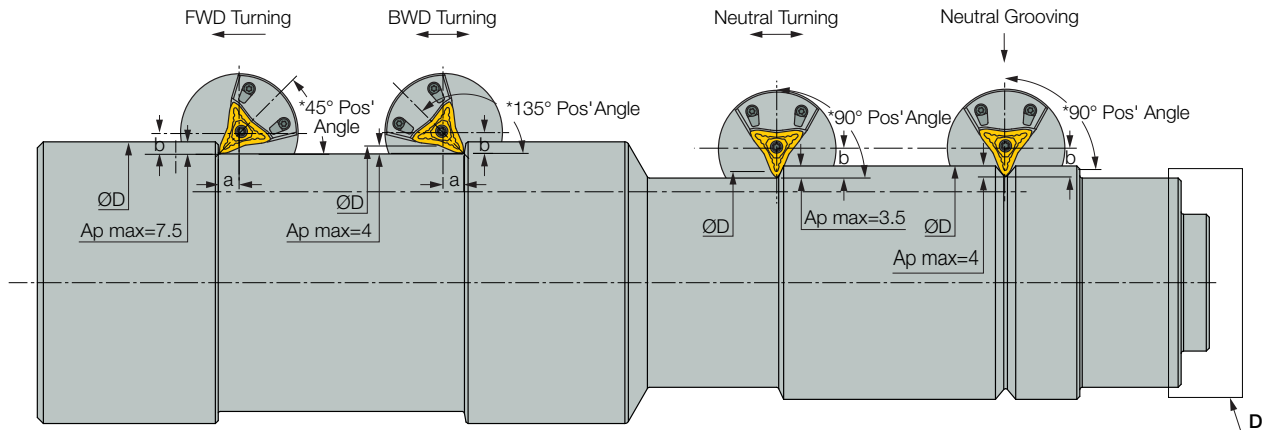

Designation	h	Direction	a	b	KAPR	W min	D min	D max
C4 SMXCN-16-SL-H65-Y	65	FWD Turning ( $A_p < 4$ )	11.2	11.2	91.5°			180
		FWD Turning ( $A_p \geq 4$ )	11.2	11.2	113°			135
		Backward Turning	11.2	11.2	23°			145
		FWD Facing	11.2	11.2	91.5°	12		85
		BWD Facing	11.2	11.2	23°	12	50	90
		Neutral Grooving		15.5				205
		Neutral Turning ( $A_p < 2.5$ )		15.5		46.5°		240
Neutral Turning ( $A_p \geq 2.5$ )		15.5		68°		220		
C5 SMXCN-16-SL-H80-Y	80	FWD Turning ( $A_p < 4$ )	11.2	11.2	91.5°			220
		FWD Turning ( $A_p \geq 4$ )	11.2	11.2	113°			185
		Backward Turning	11.2	11.2	23°			195
		FWD Facing	11.2	11.2	91.5°	17		110
		BWD Facing	11.2	11.2	23°	17	50	115
		Neutral Grooving		15.5				250
		Neutral Turning ( $A_p < 2.5$ )		15.5		46.5°		265
Neutral Turning ( $A_p \geq 2.5$ )		15.5		68°		250		
C6 SMXCN-16-SL-H100-Y	100	FWD Turning ( $A_p < 4$ )	11.2	11.2	91.5°			265
		FWD Turning ( $A_p \geq 4$ )	11.2	11.2	113°			235
		Backward Turning	11.2	11.2	23°			250
		FWD Facing	11.2	11.2	91.5°	24		120
		BWD Facing	11.2	11.2	23°	24	50	125
		Neutral Grooving		15.5				290
		Neutral Turning ( $A_p < 2.5$ )		15.5		46.5°		305
Neutral Turning ( $A_p \geq 2.5$ )		15.5		68°		295		
C8 SMXCN-16-SL-H100-Y	100	FWD Turning ( $A_p < 4$ )	11.2	11.2	91.5°			205
		FWD Turning ( $A_p \geq 4$ )	11.2	11.2	113°			190
		Backward Turning	11.2	11.2	23°			200
		FWD Facing	11.2	11.2	91.5°	32		120
		BWD Facing	11.2	11.2	23°	32	50	125
		Neutral Grooving		15.5				215
		Neutral Turning ( $A_p < 2.5$ )		15.5		46.5°		230
Neutral Turning ( $A_p \geq 2.5$ )		15.5		68°		210		

\*ANGLE ACCORDING TO KEY ORIENTATION

